

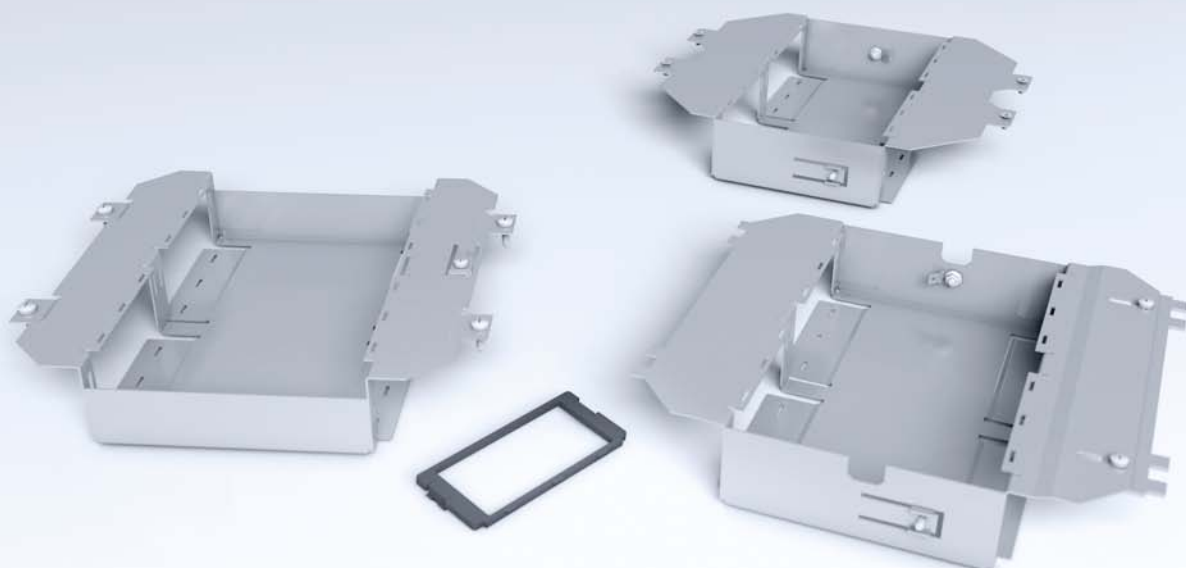

Mounting box inserts

Assembly instruction



Mounting box inserts

Assembly instruction

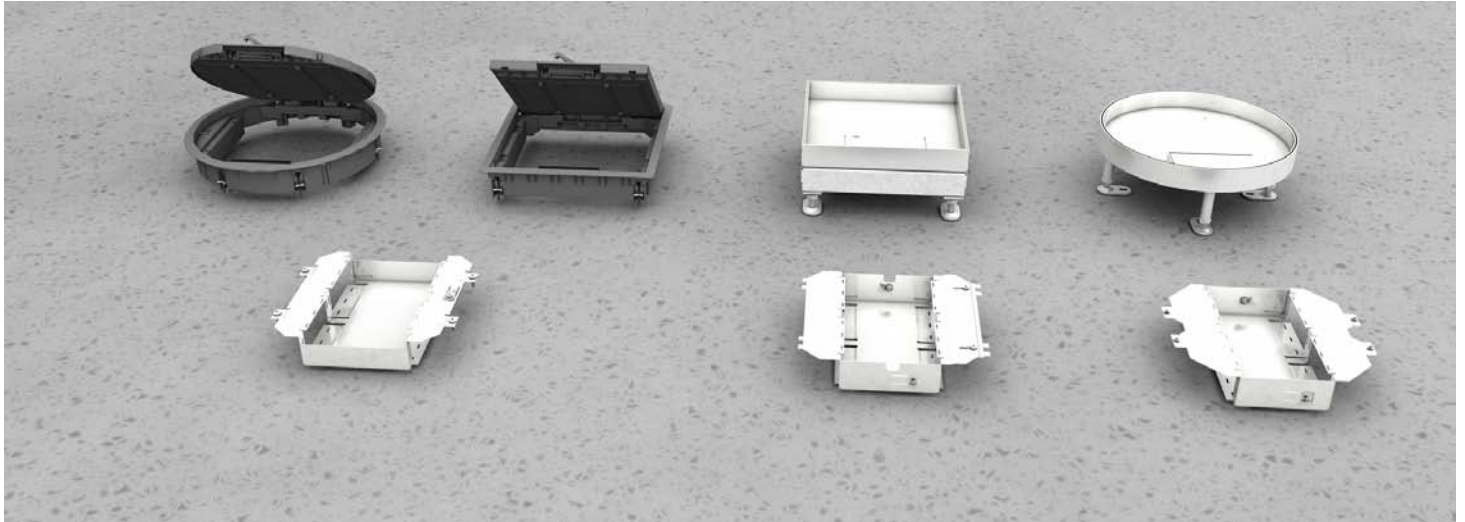

Mounting box insert made of galvanised steel plate. For round or quadrangular installation units made of plastic or stainless steel. For up to four installation devices of 45 x 45 mm and of six data single jacks. Suitable for floor constructions of at least 65 mm.

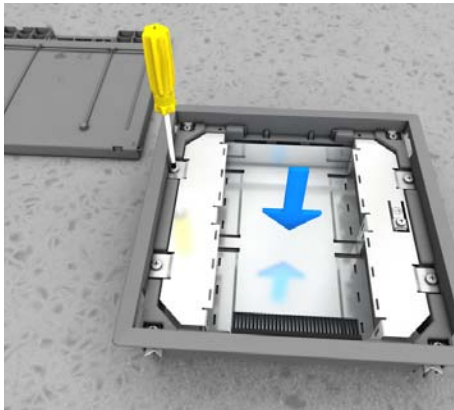

1 | Mounting box insert made of plastic UGE3-VRK 4

Put mounting box insert into quadrangular or round plastic installation unit from the top and tighten it using four thread-rolling screws.

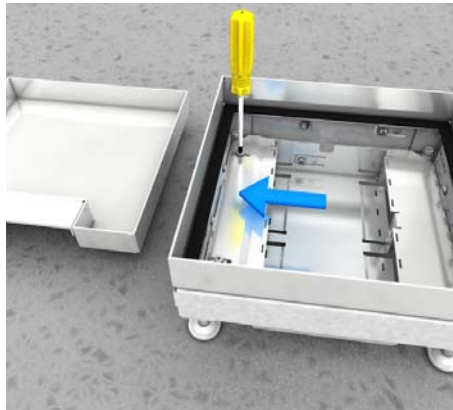

2 | Mounting box insert made of stainless steel UGE3-VE 4

Put mounting box insert sideways into quadrangular stainless steel installation unit and fix it with two slide controls in the existing snap-in holes of the levelling unit.

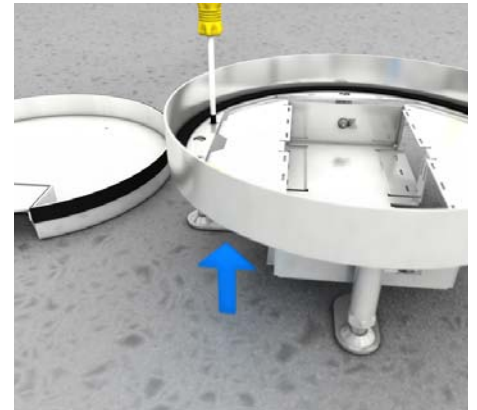

3 | Mounting box insert made of stainless steel UGE3-RE 4

Put mounting box insert into round stainless steel installation unit from the bottom and tighten it with the frame by using four countersunk head screws.

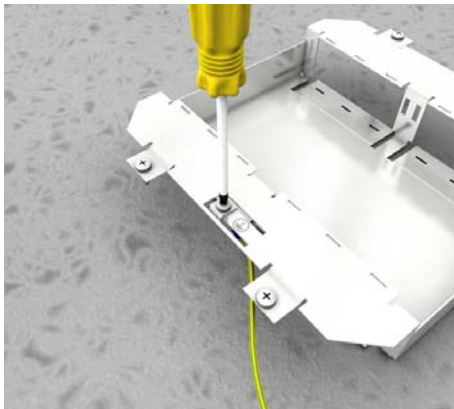

4 | Equipotential bonding steel plate

For the equipotential bonding screw the grounding connection with the grounding strap. All steel sheet parts must be included in the equipotential bonding.

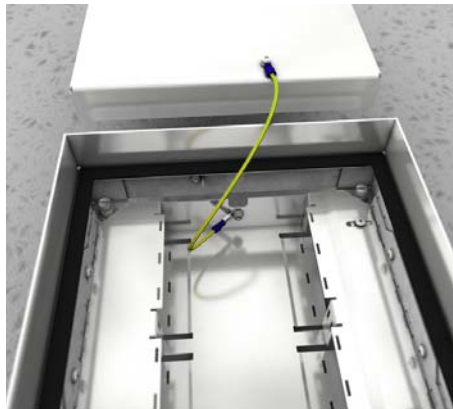

5 | Equipotential bonding cover

Create equipotential bonding between cover and frame with plug-in earth conductor.

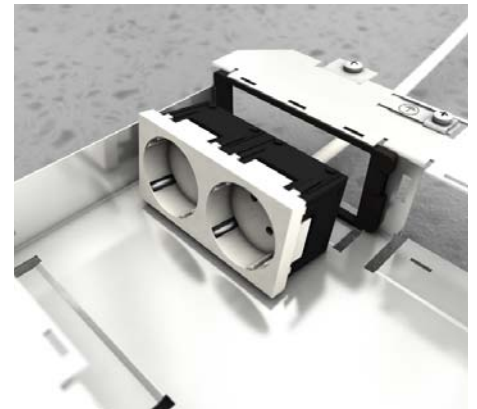

6 | Grounded contact socket 33°

Louwer (UGE3-2-UST-S) in the mounting box head-on. Afterwards, snap in the grounded contact socket (45 x 45 mm) head-on and mount the connector cable. Up to two dual grounded contact sockets can be used per mounting box insert.

Device inserts

Assembly instruction

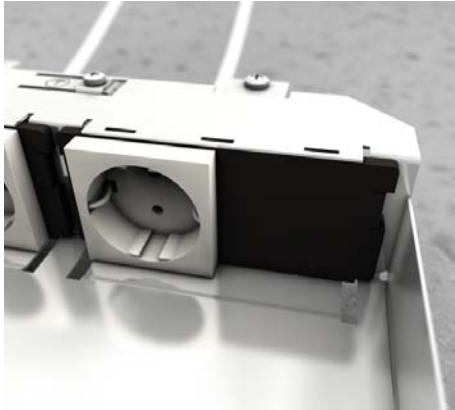

7 | Grounded contact socket 0°

Louver (UGEE-1-UST-S) in the mounting box head-on. Afterwards, snap in the grounded contact socket (45 x 45 mm) head-on and mount the connector cable. Up to two grounded contact sockets can be used per mounting box insert.

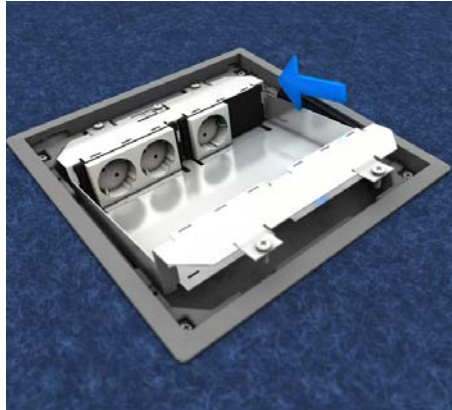

8 | Installation unit

Put the mounting box insert with its power engineering components sideways from the top in the installation unit.

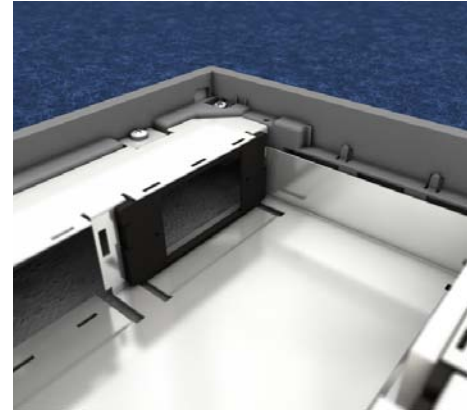

9 | Insert plate

Louver (UGEE-1-DEP-S) head-on in the mounting box opposite the power engineering components installation unit.

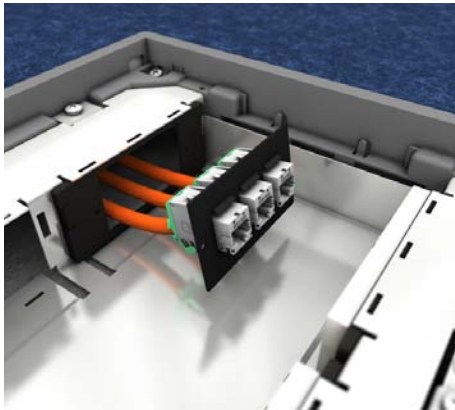

10 | Data equipment

The connected data single jacks are to be latched into the installation opening of the installation board (UDEP) from behind.

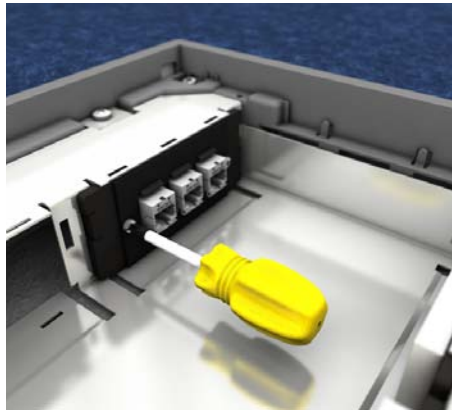

11 | Single data jack

Screw the plates with data equipment with the mounting box insert. Select the plate type depending on the manufacturer. Up to six data single jacks can be used per mounting box insert.

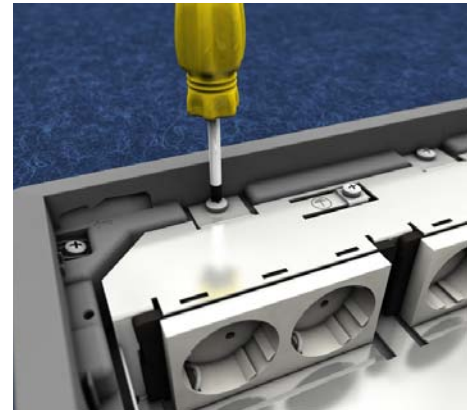

12 | Mounting box insert

Screw the mounting box insert with the installation unit.

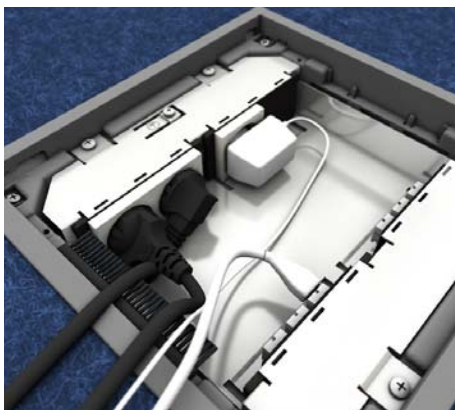

13 | Angle plugs and straight plugs

Connect the power engineering components and the data equipment via angle plugs or straight plugs. Pay attention to the dimensions and space requirements.



Errors and technical modification subject to change. Reproduction as well as electronic duplication only with our written permission. With appearance of this print all preceding documents lose their validity.

